



SRAM®

2017 Guide RE



service
manual



SRAM®

Gen.000000005128 Rev D
© 2017 SRAM, LLC

SRAM LLC WARRANTY

EXTENT OF LIMITED WARRANTY

Except as otherwise set forth herein, SRAM warrants its products to be free from defects in materials or workmanship for a period of two years after original purchase. This warranty only applies to the original owner and is not transferable. Claims under this warranty must be made through the retailer where the bicycle or the SRAM component was purchased. Original proof of purchase is required. **Except as described herein, SRAM makes no other warranties, guaranties, or representations of any type (express or implied), and all warranties (including any implied warranties of reasonable care, merchantability, or fitness for a particular purpose) are hereby disclaimed.**

LOCAL LAW

This warranty statement gives the customer specific legal rights. The customer may also have other rights which vary from state to state (USA), from province to province (Canada), and from country to country elsewhere in the world.

To the extent that this warranty statement is inconsistent with the local law, this warranty shall be deemed modified to be consistent with such law, under such local law, certain disclaimers and limitations of this warranty statement may apply to the customer. For example, some states in the United States of America, as well as some governments outside of the United States (including provinces in Canada) may:

- a. Preclude the disclaimers and limitations of this warranty statement from limiting the statutory rights of the consumer (e.g. United Kingdom).
- b. Otherwise restrict the ability of a manufacturer to enforce such disclaimers or limitations.

For Australian customers:

This SRAM limited warranty is provided in Australia by SRAM LLC, 1000 W. Fulton Market, 4th Floor, Chicago, IL, 60607, USA. To make a warranty claim please contact the retailer from whom you purchased this SRAM product. Alternatively, you may make a claim by contacting SRAM Australia, 6 Marco Court, Rowville 3178, Australia. For valid claims SRAM will, at its option, either repair or replace your SRAM product. Any expenses incurred in making the warranty claim are your responsibility. The benefits given by this warranty are additional to other rights and remedies that you may have under laws relating to our products. Our goods come with guarantees that cannot be excluded under the Australian Consumer Law. You are entitled to a replacement or refund for a major failure and for compensation for any other reasonably foreseeable loss or damage. You are also entitled to have the goods repaired or replaced if the goods fail to be of acceptable quality and the failure does not amount to a major failure.

LIMITATIONS OF LIABILITY

To the extent allowed by local law, except for the obligations specifically set forth in this warranty statement, in no event shall SRAM or its third party suppliers be liable for direct, indirect, special, incidental, or consequential damages.

LIMITATIONS OF WARRANTY

This warranty does not apply to products that have been incorrectly installed and/or adjusted according to the respective SRAM user manual. The SRAM user manuals can be found online at sram.com, rockshox.com, avidbike.com, truvatv.com, or zipp.com.

This warranty does not apply to damage to the product caused by a crash, impact, abuse of the product, non-compliance with manufacturers specifications of usage or any other circumstances in which the product has been subjected to forces or loads beyond its design.

This warranty does not apply when the product has been modified, including, but not limited to any attempt to open or repair any electronic and electronic related components, including the motor, controller, battery packs, wiring harnesses, switches, and chargers.

This warranty does not apply when the serial number or production code has been deliberately altered, defaced or removed.

This warranty does not apply to normal wear and tear. Wear and tear parts are subject to damage as a result of normal use, failure to service according to SRAM recommendations and/or riding or installation in conditions or applications other than recommended.

Wear and tear parts are identified as:

Dust seals	Stripped threads/bolts (aluminium, titanium, magnesium or steel)	Handlebar grips	Transmission gears
Bushings	Brake sleeves	Shifter grips	Spokes
Air sealing o-rings	Brake pads	Jockey wheels	Free hubs
Glide rings	Chains	Disc brake rotors	Aero bar pads
Rubber moving parts	Sprockets	Wheel braking surfaces	Corrosion
Foam rings	Cassettes	Bottomout pads	Tools
Rear shock mounting hardware and main seals	Shifter and brake cables (inner and outer)	Bearings	Motors
Upper tubes (stanchions)		Bearing races	Batteries
		Pawls	

Notwithstanding anything else set forth herein, the battery pack and charger warranty does not include damage from power surges, use of improper charger, improper maintenance, or such other misuse.

This warranty shall not cover damages caused by the use of parts of different manufacturers.

This warranty shall not cover damages caused by the use of parts that are not compatible, suitable and/or authorised by SRAM for use with SRAM components.

This warranty shall not cover damages resulting from commercial (rental) use.



SAFETY FIRST!

We care about YOU. Please, always wear your safety glasses and protective gloves when servicing SRAM products.

Protect yourself! Wear your safety gear!

TABLE OF CONTENTS

BRAKE SERVICE OVERVIEW	5
TROUBLESHOOTING.....	6
LEVER SERVICE	7
LEVER BLADE REMOVAL.....	8
PISTON ASSEMBLY REMOVAL	11
PISTON ASSEMBLY INSTALLATION.....	12
LEVER BLADE INSTALLATION.....	13
CALIPER SERVICE	16
PARTS AND TOOLS NEEDED FOR SERVICE.....	16
CALIPER EXPLODED VIEW	16
CALIPER BRAKE PAD REMOVAL.....	17
CALIPER PISTON REMOVAL.....	18
CALIPER PISTON INSTALLATION	20

Brake Service Overview

SRAM brake systems need to be serviced periodically to optimize braking function. If brake fluid is leaking from any area of the brake there may be damage or wear and tear to the internal moving parts. If the system has been contaminated with the wrong fluid there may be damage to all rubber and plastic internal parts. If your brake was damaged in a crash there may be damage to the lever blade, pushrod, and housing assemblies. Inspect and replace these parts to restore proper brake function.

Your product's appearance may differ from the pictures contained in this publication.

SAFETY INSTRUCTIONS

- Servicing your brakes removes all of the brake fluid from the system. You must bleed your brakes after you service the brake caliper and/or lever.
- Always wear safety glasses and nitrile gloves when working with DOT fluid.
- Place an oil pan on the floor where you will be working on the brake.
- Used DOT fluid should be recycled or disposed of in accordance to local and federal regulations.
- Never pour DOT fluid down a sewage or drainage system or into the ground or a body of water.
- DOT fluids will damage painted surfaces. If any fluid comes in contact with a painted surface (i.e. your frame) or printing on the brakes, wipe it off immediately and clean it with isopropyl alcohol or water. Damage to painted and/or printed surfaces by DOT fluid is not covered under warranty.
- Do not allow any brake fluid to come in contact with the brake pads. If this occurs, the pads are contaminated and must be replaced.
- For best results, use only SRAM High-Performance DOT 5.1 fluid. If SRAM fluid is not available, only use DOT 5.1 or 4 fluid.
Do not use mineral oil or DOT 5 fluid.

NOTICE

Do not use mineral oil or DOT 5 fluid. Do not use tools, rags, or syringes that are contaminated with mineral oil or DOT 5 fluid. Using contaminated materials will result in permanent damage to the seals and reduce braking performance.

Troubleshooting

If your levers have excessive brake lever throw, it may be a result of the pistons sticking in the caliper. Before bleeding the system, you can try to loosen the sticky piston by performing the following steps:

1. Clamp the bicycle into a bicycle work stand.
2. Remove the wheel from the affected caliper.
3. Squeeze the brake lever several times until the brake pads nearly contact one another.
4. Insert the pad spreader between the brake pads to spread the pads to the full width of the clip.
5. Remove the pad spreader.
6. Repeat steps 3-5.
7. Reinstall the wheel.
8. Squeeze the brake lever several times to position the brake pads to the proper distance from the rotor.
9. Center the caliper on the rotor if necessary.
10. Spin the wheel and check the brake function. The pistons should move freely and there should not be excessive brake lever throw.

If there is no improvement in the brake function, proceed with caliper service.

Lever Service

Parts and Tools Needed for Service

- Safety glasses
- Nitrile gloves
- Oil pan
- Isopropyl alcohol
- Clean, lint-free rag
- SRAM High-Performance DOT 5.1 fluid, or DOT 4 fluid, or Avid DOT Assembly Grease
- Needle nose pliers
- Lever Internals Guide R/RE/DB5 Kit
- Long-tipped internal snap ring pliers
- Pick with a 90° bent tip
- T8, T10, & T25 TORX® wrench
- T8 & T10 TORX® bit socket
- 8 mm flare nut wrench
- 4 mm hex wrench
- Torque wrench
- Loctite® Threadlocker Blue 242®

Guide RE Lever Exploded View

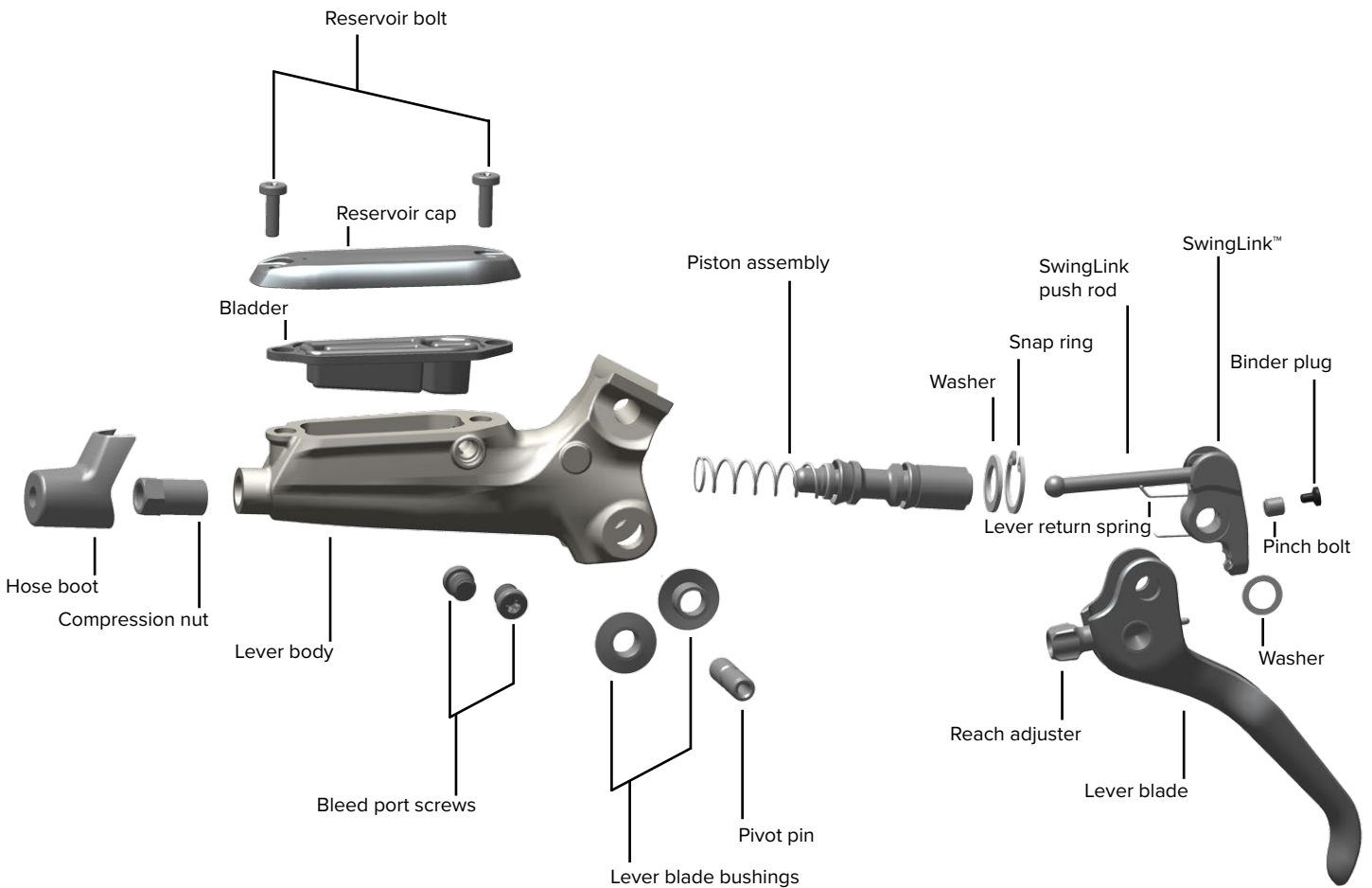

NOTICE

DOT fluid will damage painted surfaces. If any fluid comes in contact with a painted surface (i.e. your frame) or printing on the brakes, wipe it off immediately and clean it with isopropyl alcohol or water. Damage to painted and/or printed surfaces by DOT fluid is not covered under warranty.

- 1 Use a T25 TORX® wrench or a 4 mm hex wrench to remove the brake clamp bolt from the discrete clamp, MMX, or XLoc™ (XLoc requires removal of the shifter) and remove the brake lever from the handlebar.
- 2 Pull the hose boot off the compression nut and slide it down the hose.



- 3 Remove the hose compression nut, then pull the brake hose and compression nut from the brake lever body.



- 4 Pour the brake fluid into an oil pan. Squeeze the lever blade to pump out the excess brake fluid from inside the lever body.

NOTICE

If the system has been contaminated with mineral oil or DOT 5 fluid, flush all the parts with soapy water, rinse, and allow all parts to dry prior to rebuilding. Install all new seals and a new hose.

For best results, use only SRAM High-Performance DOT 5.1 fluid. If SRAM fluid is not available, only use DOT 5.1 or 4 fluid.



5 Remove the reservoir cap bolts from the reservoir cap.



6 Remove the reservoir cover and bladder from the lever body.



7 Pour the remaining fluid from the brake lever body into a pan.



8 Separate the bladder from the reservoir cover.
Spray isopropyl alcohol on the bladder and the reservoir cover and clean them with a rag.

NOTICE

All components must be completely dry before reinstalling them. Moisture residue from cleaning the bladder can leak out of the bladder as it dries, which can be misinterpreted as a system leak when it is not.



9 Remove the binder plug.



Pick

10 Remove the pinch bolt.



T8 TORX® wrench

11 Push out the pivot pin.



13 Remove the lever blade from the lever body.

The lever blade has four pieces, the lever blade, the cam/push rod assembly, a washer, and the lever return spring. To hold all pieces together you may reinstall the lever pivot pin and gently set aside.



Piston Assembly Removal

- 1 Remove the lever blade bushings from both sides of the lever.



- 2 Use long-tipped internal snap ring pliers to apply downward pressure to the lever body and remove the snap ring. Turn the lever body upside down to allow the washer to fall out of the body.

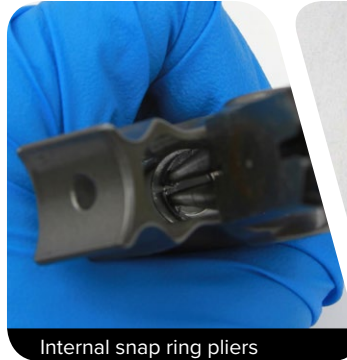

Internal snap ring pliers

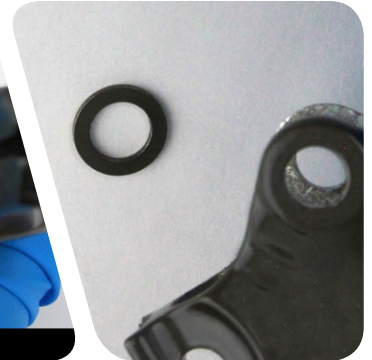

- 3 Remove the piston assembly.

⚠ CAUTION - EYE HAZARD

Wear safety glasses.

Do not look directly into the lever body while performing this step. The internal piston/spring assembly is preloaded and will come out of the lever body quickly, which can result in injury.



Needle nose pliers

- 4 Spray isopropyl alcohol on the lever body and the lever blade and clean them with a rag.



NOTICE

DOT fluid will damage painted surfaces. If any fluid comes in contact with a painted surface (i.e. your frame) or printing on the brakes, wipe it off immediately and clean it with isopropyl alcohol or water. Damage to painted and/or printed surfaces by DOT fluid is not covered under warranty.

- 1 Submerge a new piston assembly into SRAM High-Performance DOT 5.1 fluid to lubricate the piston assembly.

You can also use AVID DOT Grease, or DOT 5.1 or 4 compatible grease, as a lubricant.



SRAM High-Performance DOT 5.1 fluid

- 2 Install the new piston assembly.
Spray isopropyl alcohol on the lever body and both of your gloves and clean the lever body and your gloves with a rag.



- 3 Install the washer on the piston assembly.
Use long-tipped internal snap ring pliers to push the piston assembly into the lever body, and secure the snap ring in its groove. Orient the snap ring eyelets opposite the opening in the lever body.
You can also use a 10 mm deep socket against the snap ring to push the piston/bladder/snap ring assembly into the lever body.



Lever Blade Installation

- 1 Insert the lever blade bushings into both sides of the lever.



- 2 Insert the lever assembly into the lever body, placing the push rod into the piston and lever return spring on the lever body.



Make sure the reach adjuster knob is seated in the cam hole and the lever return spring is seated as pictured. The reach adjuster must be seated in the cam hole. If it is not set properly you will be unable to adjust your lever reach.



- 3 Line up the cam and lever blade with the holes in the lever body, then press the pivot pin through the holes.



- 4** Apply a small amount of Loctite® Threadlocker Blue 242® onto the pinch bolt.
Thread the pinch bolt into the lever body. Tighten the pinch bolt to 2.7-3.2 N·m (24-28 in-lb).



- 5** Install a new binder bolt plug.



- 6** Press the bladder into the reservoir cap. Ensure the bladder is flush with the reservoir cap.



- 7** Insert the reservoir cap/bladder assembly into the lever body.



- 8 Tighten each reservoir cap bolt to 2.7-3.2 N·m (24-28 in-lb).



- 9 Cut the hose to install a new barb and compression fitting.

NOTICE

You must install a new hose barb and compression fitting before reconnecting the brake lever to the hose.



- 10 Apply DOT grease to the hose barb threads. Thread the hose barb into the hose until it is flush with the end of the hose.

NOTICE

Do not overtighten the hose barb. Overtightening may cause damage to the hose liner.



- 11 Install the compression nut onto the hose.



12 Thread the compression fitting over the hose barb, counter-clockwise, until it is flush or slightly lower than the hose barb.

The compression fitting is reverse threaded.

Apply DOT grease to the outside of the compression fitting and the threads of the compression nut.

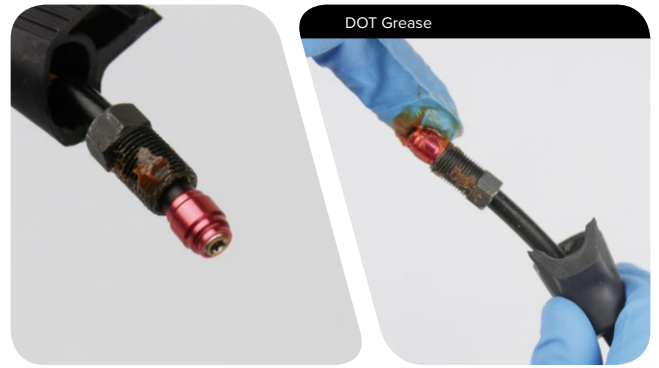

13 Install the compression fitting and nut into the lever.



14 The Guide RE lever comes in with either a traditional or Stealth-a-Majig compression nut fittings.

Traditional: compression nuts, tighten to 5-6 N-m (44-52 in-lb).

Stealth-a-Majig: compression nuts, tighten to 8 N-m (71 in-lb).

Spray isopropyl alcohol on the lever body and clean it with a rag.



Caliper Service

We recommend that you have your SRAM brakes serviced by a qualified bicycle mechanic. Servicing SRAM brakes knowledge of brake components as well as the special tools and oils used for service.

For exploded diagram and part number information, please refer to the Spare Parts Catalog available on our website at sram.com/service. For order information, please contact your local SRAM distributor or dealer.

Information contained in this publication is subject to change at any time without prior notice. For the latest technical information, please visit our website at sram.com/service.

Your product's appearance may differ from the pictures contained in this publication

Parts and Tools Needed for Service

- Safety glasses
- Nitrile gloves
- Oil pan
- Isopropyl alcohol
- Clean, lint-free rag
- Code bleed block
- 2.5 mm hex wrench
- Air compressor with a rubber tipped blow chuck
- Needle Nose Pliers
- Service Kit, Caliper - Code/Guide RE
- (Optional) Piston Kit - Code/Guide RE
- Pick
- Rubber pad or flat section of inner tube
- Digital caliper
- 5 mm hex wrench
- 5 mm hex bit socket
- Torque wrench
- SRAM High-Performance 5.1 DOT fluid, or Avid DOT Assembly Grease
- 8 mm flare nut wrench
- 8 mm flare nut crowfoot
- Hydraulic Disc Brake Hose Flitting Kit

Caliper Exploded View

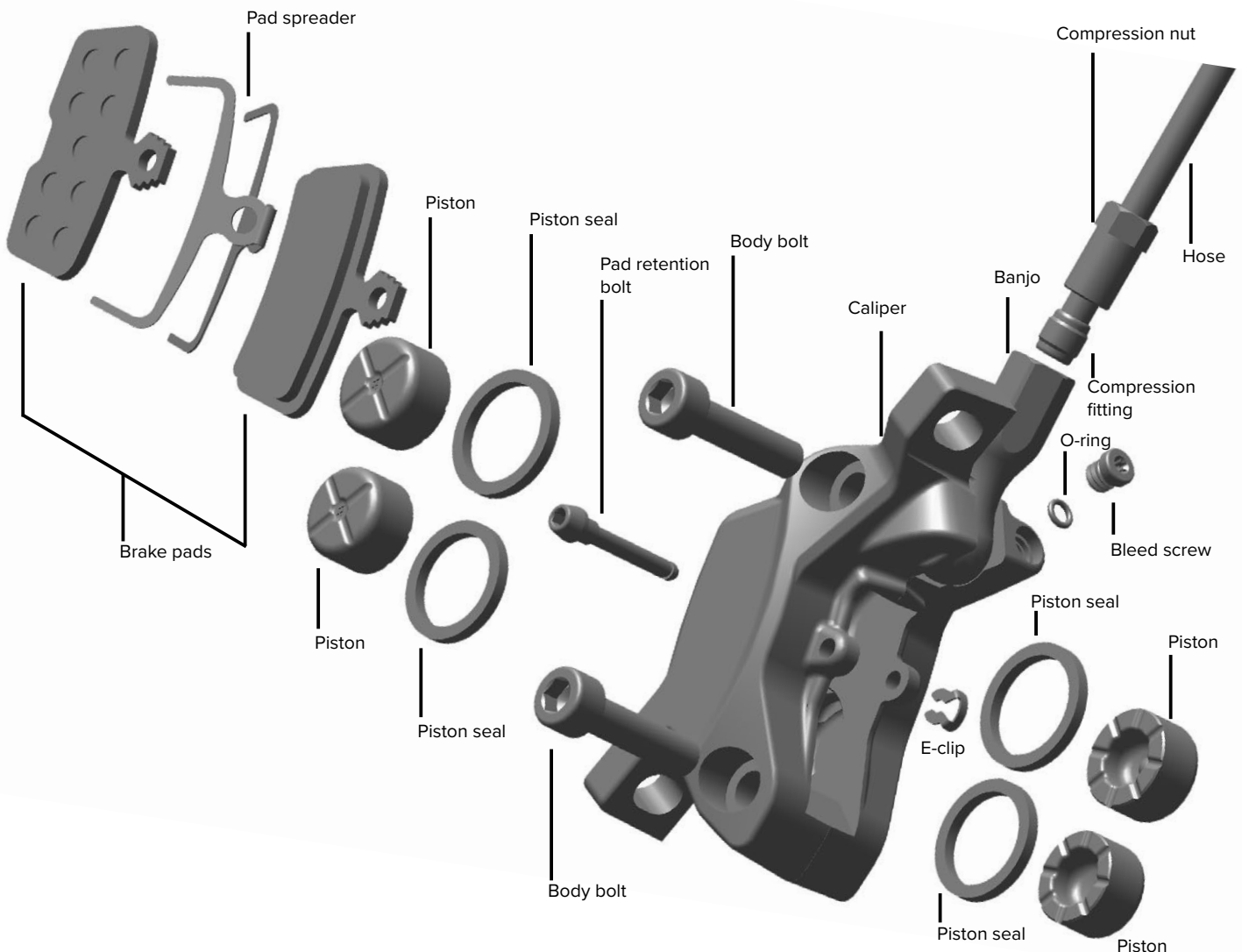

NOTICE

DOT fluid will damage painted surfaces. If any fluid comes in contact with a painted surface (i.e. your frame) or printing on the brakes, wipe it off immediately and clean it with isopropyl alcohol or water. Damage to painted and/or printed surfaces by DOT fluid is not covered under warranty.

- 1 Remove the brake caliper from the fork or frame.
Remove the caliper mounting bracket and hardware from the caliper then set them aside in the order that they were removed.

- 2 Remove the pad spreader.
Remove the E-clip from the pad retention bolt.
Remove the pad retention bolt from the caliper.



- 3 Remove the brake pads from the caliper.

NOTICE

Brake pads must be replaced if the total thickness of the backing plate and pad friction material is less than 3 mm.



NOTICE

DOT fluid will damage painted surfaces. If any fluid comes in contact with a painted surface (i.e. your frame) or printing on the brakes, wipe it off immediately and clean it with isopropyl alcohol or water. Damage to painted and/or printed surfaces by DOT fluid is not covered under warranty.

- 1 Remove the compression nut and hose.



- 2 Remove the body bolts then separate the caliper body.



- 3 Set aside the banjo. Align the blow chuck nozzle with the caliper body port.



- 4 Press the caliper down then blow air into the caliper body port.

⚠ CAUTION - EYE HAZARD

Wear safety glasses.

The caliper piston may dislodge rapidly from the caliper, which can lead to bodily injury or damage to the parts. Point the caliper piston toward a rubber surface before forcing air into the caliper.



5 Remove the pistons.



6 Pierce the piston seal with a pick, then remove the piston seal from inside both the inboard and outboard half of the caliper body.
Install a new seal inside each caliper body half.

NOTICE

Do not scratch the seal gland with a pick. It could result in a slow fluid leak when the brake is applied.



7 Spray isopropyl alcohol on the caliper halves and both of your gloves, and clean them with a rag.



NOTICE

DOT fluid will damage painted surfaces. If any fluid comes in contact with a painted surface (i.e. your frame) or printing on the brakes, wipe it off immediately and clean it with isopropyl alcohol or water. Damage to painted and/or printed surfaces by DOT fluid is not covered under warranty.

- 1 Inspect the caliper pistons for damage and replace the pistons if necessary.

Use your gloved finger to apply a small amount of SRAM High-Performance DOT 5.1 fluid to the circumference of each piston. Install the pistons into each half of the caliper body.

NOTICE

For the best braking performance, use only SRAM High-Performance 5.1 DOT fluid. If SRAM fluid is not available, use only DOT 5.1 or 4 fluid. Do not use grease. Grease will prevent the pistons from fully retracting into the caliper bores which will reduce braking performance.



- 2 Remove the caliper o-rings and install new o-rings onto the inboard and outboard caliper body halves.

Add a small amount of DOT compatible grease onto the installed o-rings to help them stay in place, as you assemble the caliper.



- 3 Align the caliper body halves then install the caliper body bolts two full turns.

Install the banjo.



- 4 Tighten each caliper body bolt to 4.4-5.4 N-m (39-48 in-lb).



5 mm hex wrench

4.4-5.4 N-m (39-48 in-lb)

- 5 Cut the hose to install a new barb and compression fitting.



- 6 Apply DOT grease to the hose barb threads. Thread the hose barb into the hose until it is flush with the end of the hose.

NOTICE

Do not overtighten the hose barb. Overtightening may cause damage to the hose liner.



- 7 Install the compression nut onto the hose.



- 8 Thread the compression fitting over the hose barb, counter-clockwise, until it is flush or slightly lower than the hose barb.

The compression fitting is reverse threaded.

Apply DOT grease to the outside of the compression fitting and the threads of the compression nut.

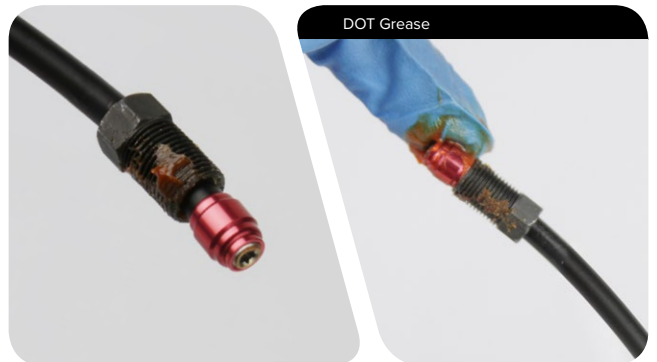

- 9 Install the compression fitting and nut into the caliper.



- 10 Tighten the compression nut and compression fitting to 9.8-11.8 N·m (87-104 in·lb).
Install a crowfoot socket at 90 degrees to the torque wrench to ensure an accurate torque value.



- 11 Insert the bleed block.

⚠ WARNING

You must bleed your brakes before reinstalling the brake pads. Installing the brake pads prior to bleeding the brakes could contaminate the brake pads and could lead to a brake failure.



- 12 Spray isopropyl alcohol on the caliper and clean it with a rag.



⚠ CAUTION

Servicing your brakes removes all of the fluid from the system. You must bleed the brakes after you service the brake caliper and/or lever. For brake bleed, brake hose shortening, and brake pad replacement instructions, [visit www.sram.com/service](http://www.sram.com/service).

This publication includes trademarks and registered trademarks of the following companies:

TORX® is a registered trademark of Acument Intellectual Properties, LLC.

Loctite® and Threadlocker Blue 242® are registered trademarks of Henkel Corporation

SRAM®

www.sram.com



ASIAN HEADQUARTERS

SRAM Taiwan
No. 1598-8 Chung Shan Road
Shen Kang Hsiang, Taichung City
Taiwan R.O.C.

WORLD HEADQUARTERS

SRAM LLC
1000 W. Fulton Market, 4th Floor
Chicago, Illinois 60607
USA

EUROPEAN HEADQUARTERS

SRAM Europe
Paasbosweg 14-16
3862ZS Nijkerk
The Netherlands